

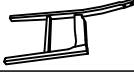

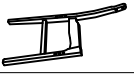

# ASSEMBLY INSTRUCTIONS FOR ACME FURNITURE

## MODEL#DN02313/DN02314

Thank you for purchasing the quality product. Be sure to check all packing material carefully for small parts which may have come loose inside the carton during shipment. Separate, identify and count all parts and metal hardware. Compare with all parts list to be sure all parts are present. If any part(s) are missing or damaged, please contact your local furniture dealer. For efficient and speedy service, please indicate the model number and code letter of part(s) needed.

\*\*\* Do not fully tighten screws until fully assembled \*\*\*

DESCRIPTION	COMPONENT PARTS	
	PART NAME	Q'TY(PCS)
①	RIGHT SIDE FRAME 	1
②	LEFT SIDE FRAME 	1
③	FRONT STRETCHER 	1
④	BACK STRETCHER 	1
⑤	TOP REST 	1
⑥	CUSHION SEAT 	1

### HARDWARE REQUIRED

Ⓐ		JCBC M6 x 30mm + S/W M6 + F/W M6 x 13mm	4	PCS
Ⓑ		JCBC M6 x 50mm + S/W M6 + F/W M6 x 13mm	2	PCS
Ⓒ		JCBC M6 x 55mm + S/W M6 + F/W M6 x 13mm	2	PCS
Ⓓ		ALLEN KEY M4	1	PC
Ⓔ		L BRACKET	4	PCS
Ⓕ		PH SCREW M4 x 12mm	8	PCS
Ⓖ		WOOD DOWEL M8 x 25mm	2	PCS
Ⓗ		PVC NAIL 5/8"	4	PCS
Ⓘ		WOOD BUTTON Ø 14.5mm	4	PCS

### TOOLS NEEDED

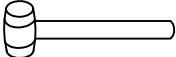
 (NOT PROVIDED)

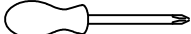
 (NOT PROVIDED)

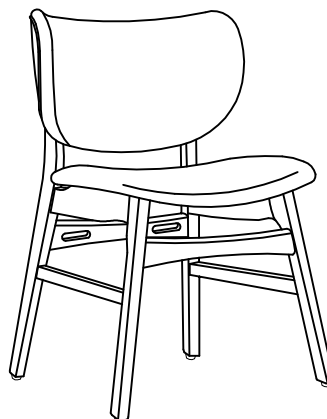

### Attention

\*\* Some number parts listed on the instruction sheet may not be in parts bag as they may already be assembled. Carefully check parts and packing materials prior to ordering replacements.

# How to assemble:

## STEP 1

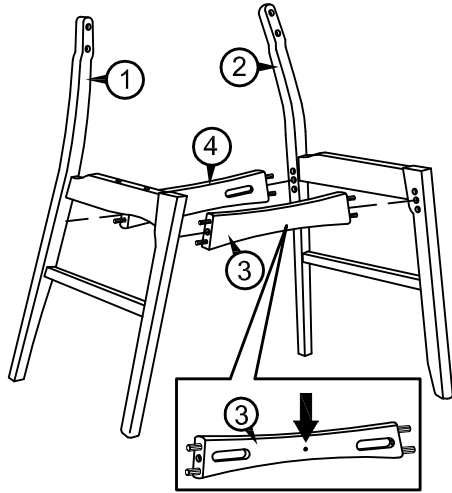

Front Stretcher has a small hole for identification.

## STEP 2

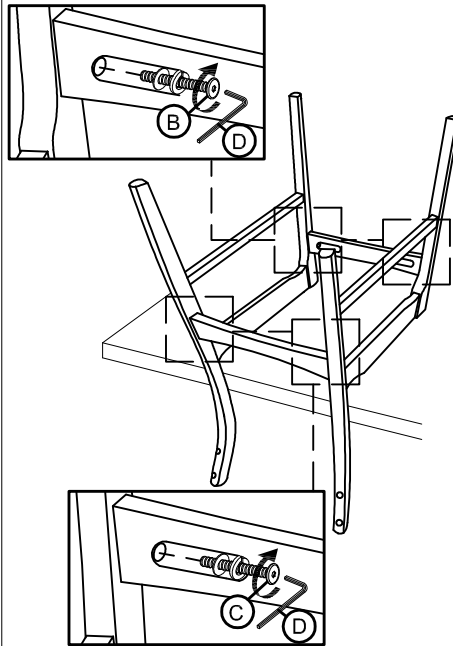

## STEP 3

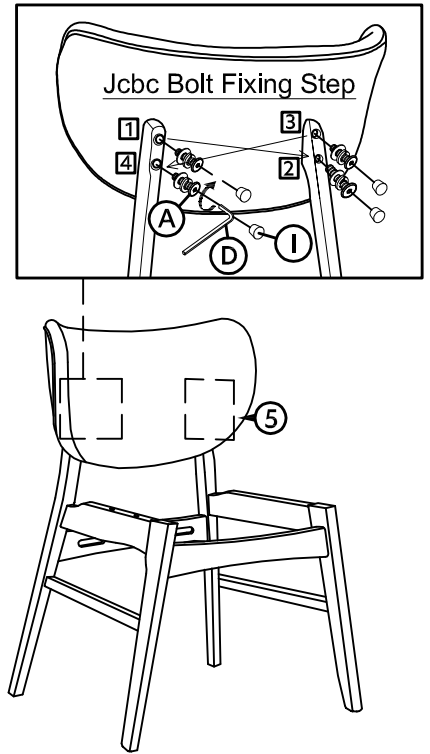

## STEP 4

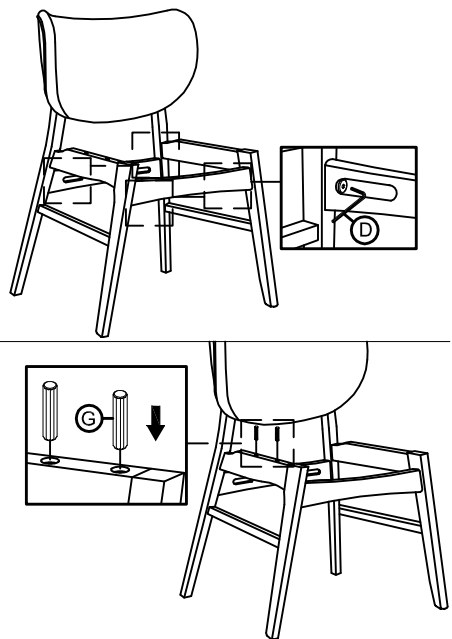

## STEP 5

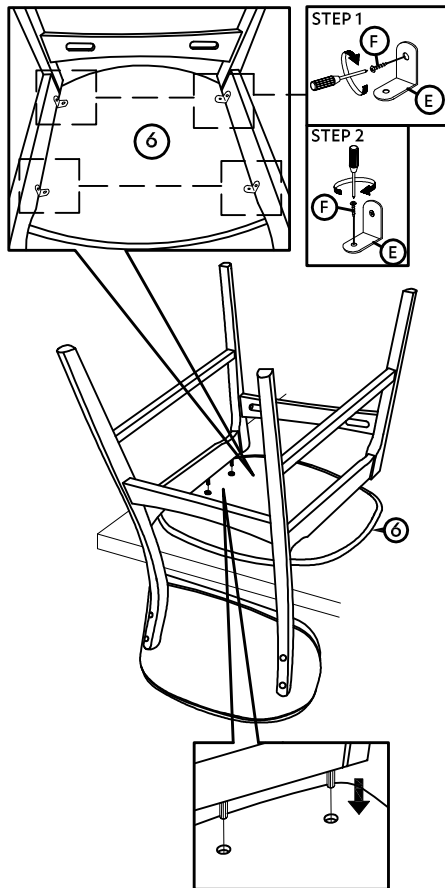

## STEP 6

